

Contents

- 1 Revision History**
- 2 General**
- 3 Specifications**
- 4 Contents**
- 5 Cable Preparation**
- 6 Closure Preparation**
- 7 Sheath and CSM Retention**
- 8 Cable Seal and End Plate Assembly**
- 9 Closure Re-assembly & Splicing**
- 10 Closure Closing and Storage**

1.0 Revision History

Release #	Date	Remarks
1.0	1/5/2005	Initial Release

2.0 General

2.1 Overview *Refer to Figure 1*

The Multilink Starfighter™ 4048D is a fully sealed medium capacity dome style fiber optic splice closure designed for traditional optical fiber splicing and FTTH applications. The closure can be installed in Aerial, Underground, Pedestal and Wall mount applications supporting the various types of cable designs and splicing methods. Incorporated into the closure is a sealing system that requires no special tooling, mastics, adhesives nor thermal sealing products. All cabling is individually sealed allowing for entry or re-entry to the closure without disturbing existing cabling.



Figure 1

The 4048D consist of six (6) primary components. *Refer to Figure 2*

2.2 Split End Plate

Split end plate allows for installing mid-accessed cables. Split end plates are gasketed and secured to one another with three hex head bolts. End plates have two feeder or express ports, four branch or lateral/drop ports, a bonding and grounding lug, and an “F” pressure-testing valve. Additionally, the endplate supports the installation of closure support bracketing for aerial, wall, pedestal or below-grade mounting.

2.3 Integrated Slack Storage Basket

The integrated slack storage basket is designed to allow the storage and routing of all types of fiber bundles. A hinged cover allows for ease in accessing and managing stored slack.

2.4 Tray Stacking Module

The tray stacking module secures up to (4)* four 4048-SSTP type splice trays. The module has a tray-locking feature that permits each of the splice trays to be locked in a temporary position to allow access to the individual fibers in trays beneath.

*The closure can be equipped with a passive coupler cassette which utilizes one tray position reducing the capacity to three trays.

2.5 “O” Ring

The “O” ring provides for a seal between the Dome and Split End Plates.

2.6 “V” Band

An impact resistant plastic “V” band secures the Dome to the Split End Plates. The “V” band has a feature that supports a locking mechanism for field security.

2.7 Dome

Protects the internal components and allows for 360-degree access to the splice.

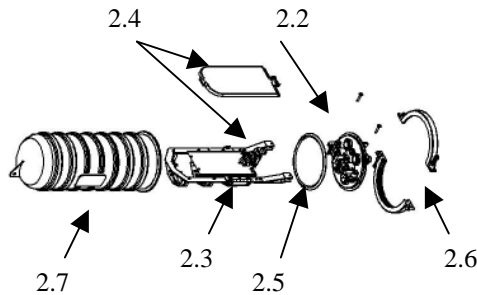

Figure 2

3.0 Specifications

3.1 Cable Entry & Ordering Information Refer to Figure 3 & Table 1

Maximum Cable entries: 6*

Feeder/Express (2) ports: .3" to .75" (7.6mm) to (19.05mm).

Branch/Lateral/Drop (4) ports: .3"- .63" (7.6mm) to (16mm)

*Multiport grommets for supporting fiber drops for FTTH are available

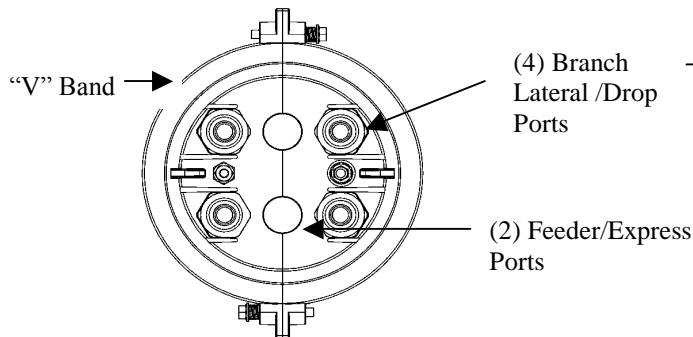

Figure 3

Table 1 - Dome Fittings & Inserts for Branch Lateral/Drop Cables

Part Number	Description
10-8365	4048 Starfighter Fiber Optic Dome Splice Closure
10-8362	4000/4048D Starfighter Aerial Hangar Kit
10-8007	4048-SSTP Splice Tray, 24 Single/48 Mass Fusion
10-8181	4048D-CAK Cable Addition Kit
<i>Individual Grommets</i>	
10-8084	4 port Insert .20" to .24" (5mm to 6mm)
10-8087	4 port Insert .16" to .20" (4mm to 5mm)
10-8085	3 port Insert .24" to .28" (6.1mm to 7.1mm)
10-8090	3 port Insert .16" to .20" (4mm to 5mm)
10-8092	3 port Flat Insert (Corning, Alcatel, Sumitomo) drop cabling
10-8091	2 port Insert .25" to .29" (6.3mm to 7.4mm)
10-8088	1 port Insert .27" to .34" (6.8mm to 8.6mm) Included in Basic Closure & 4048D-CAK

3.2 Closure Dimensions Refer to Figure 4

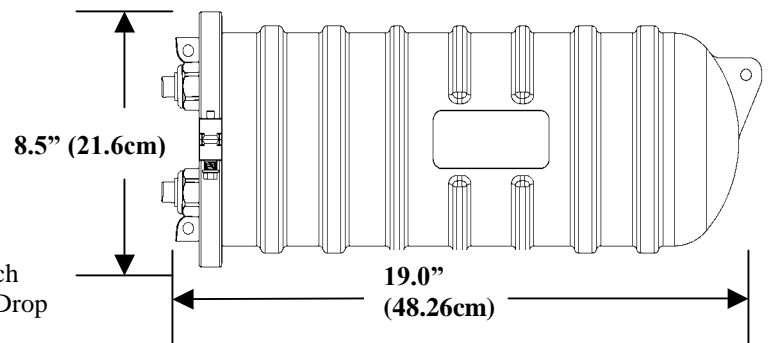

Figure 4

Length	19" (48.3cm)
Diameter	8.5" (21.6cm)
Weight	7.5 lbs. (3.4 kg)

3.3 Tray & Splice Capacity Refer to Figure 5

- (4) 4048-SSTP Splice Trays
- * (24) Single Fused Fibers
- (192) Mass Fused fibers

*NOTE: All single fusion splice organizers allow for double stacking splice sleeves.

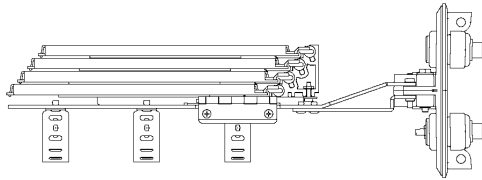

Figure 5

4.0 Contents

4.01 The basic closure is equipped with the following;

- (1) Complete closure (Dome, O Ring, V Band, End Plates, and Slack Storage Module)
- (2) Multicentric Cable seals (Feeder/Express ports)
- (1) 4048D-CAK, Cable Addition Kit for securing a branch/lateral cable
- (3) Grounding/Bonding kits (RUS Compliant)
- (2) CSM/Strain relief brackets for feeder/express cabling
- (2) Silicon Gel packages (1 oz each)
- (1) 4048-SSTP Splice Tray

4.02 Additional Material Required

- Cable Cleaner or wipes
- Cable identification markers
- Pressure testing solution or equivalent
- Splice sleeves or other splicing specific material.

4.03 Tools Required

- Splicing Shears
- Splicing Equipment
- Cable Stripper
- 7/16" Nut Driver
- 3/8" Nut Driver
- #2 Phillips Head Screwdriver
- Air Pressurization source

5.0 Cable Preparation

The closure is designed for mid-accessed and full cut cable entries. The following information serves as a guideline for sheath opening lengths.

5.1 Mid-Accessed or Full Cut Cables – remove up to 96" (243.8cm) of sheath exposing the underlying kevlar, cable loose tubes, core tube or other fiber protective tubing. If armored, remove armor leaving 1" (25.4mm) of armor for bonding/grounding.

5.1.1 Cut central or outer strength members' 5.0" (127mm) from the sheath end (will be trimmed later)

5.1.2 Clean the optical bundles or outer buffer tubes with an approved cable cleaner.

5.1.3 Do not expose any fibers at this time.

5.2 Bundle Preparation Refer to figure 6

For loose tube bundles, depending on the cable manufacturer, the loose tubes may be routed directly to the appropriate splice tray and can be opened and trimmed after installation within the closure. Core tube cables', remove the core tube to within 7.0" (177.8mm) from the end of the cable sheath or armor. This tube will be routed and secured into the slack storage basket and all bundles managed within the basket later.

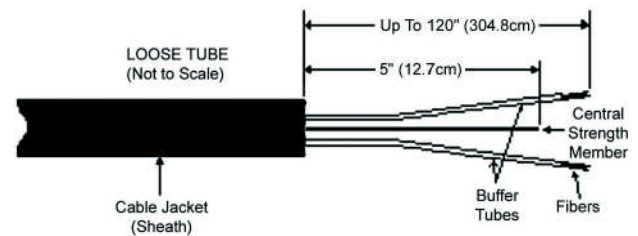

Figure 6

6.0 Closure Preparation *Refer to Figure 7*

The closure must be disassembled for installing the feeder/express cables into the multicentric grommets.

6.01 Back off the two spring loaded bolts securing the “V” band and remove.

6.02 Slide the Dome and “O” ring off and protect the “O” ring from contamination

6.03 Remove the two Phillip Head screws securing the Slack Storage Basket and set all aside.

6.04 Back off the three hex head bolts using a 7/16” Nut Driver securing the End plate sections and expose the two multicentric grommets.

6.05 Remove the two Multicentric grommets.

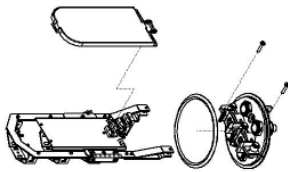

Figure 7

7.0 Sheath and CSM Retention

The following information provides installation information regarding the different types of cable sheath and bundling designs. Note that the CSM clamp provides both cable strain relief and CSM termination. If Core Tube cabling is being installed the CSM extension of the combination clamp will be removed.

Armored cable preparation requires the completion of sections 7.01 through 7.04.

7.01 Armored Cable; Slit a 1” long slit under the armor and polyethylene sheath on the opposite side of where the bond connector is to be installed and 90 degrees away from the top and bottom. *See Figure 8*

7.02 Slide the supplied Mini Bonding Connector’s bottom up to the sheath’s end ensuring that it is under the armor between the optical bundles or core tube and the armor.

7.03 Attach the connector top plate and nut to the bond clamp and tighten

7.04 Attach the perforated bond wire to the stud of the clamp and gently tighten the second nut.

NOTE: The opposite end of the bond wire will be attached to the closure’s end plate in a later step.

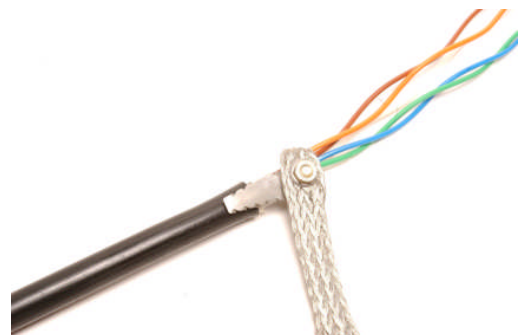
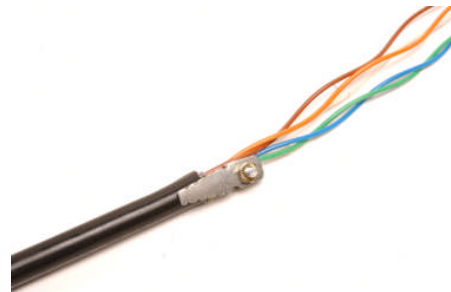
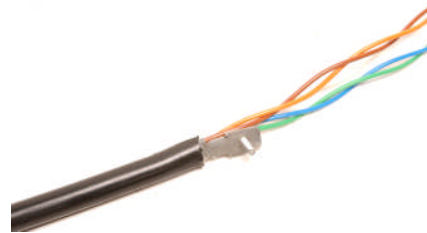

Figure 8

7.1 Strain Relief Installation *Refer to Figure 9*

Loose tube cables typically have a Central Strength Member that must be terminated to inhibit any movement. Trim the strength member to 2.5" from the sheath's end.

7.1.2 Slide the Cable Retention and CSM clamp over the CSM's end and secure the assembly to the cable sheath using one of the supplied Hose Clamps. Tighten the clamp but do not overtighten.

7.1.3 Using a standard pair of pliers, crimp the CSM clamp end to secure it to the CSM.

7.1.4 For Central core cables, break-off the CSM extension of the CSM clamp leaving the strain relief intact.

NOTE: For Outer Strength member cables, cut the strength member's flush to the sheath end.

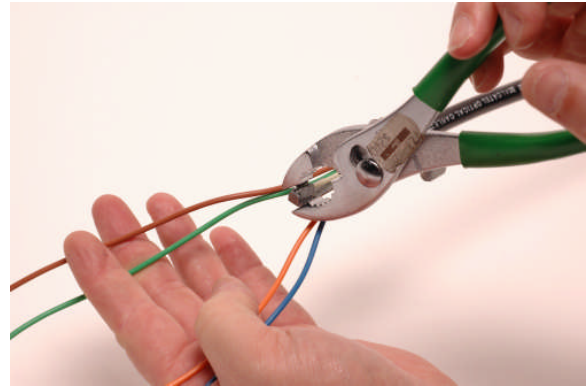

Figure 9

8.0 Cable Seal and End Plate Assembly

8.0.1 Multicentric Cable Seals *Refer to Figures 10 thru 13*

Using the measuring gauge provided in the closure kitting, follow the directions on the gauge and determine the diameter of the feeder/express cable(s) and number of layers to be removed.

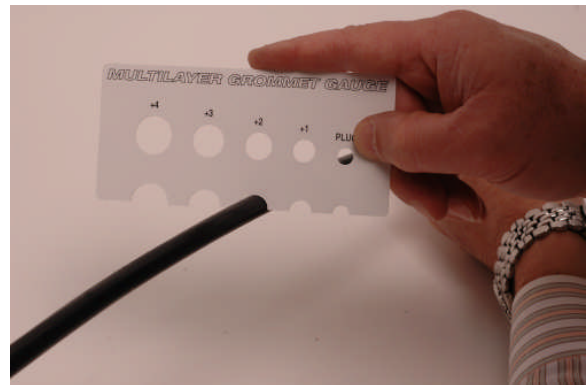
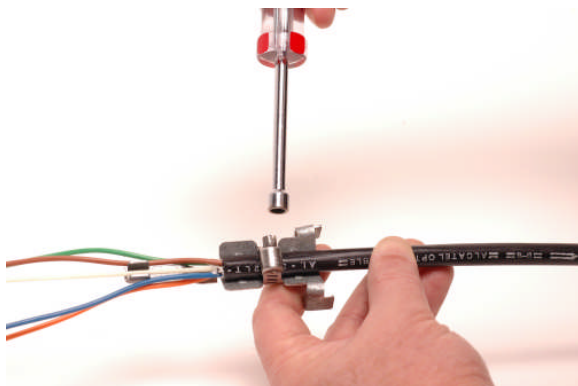

Figure 10

8.0.2 Use caution when removing layers. Splicing shears or a cable knife may be used to start the removal by placing a small nick at the point where the layer joins the grommet.



Figure 11

8.0.3 Pull on the layer at the location of the nick.



Figure 12

8.0.4 Any differential between the OD of the cable and the adjusted ID of the grommet can be made up with a layer of sealing tape included in each closure kit.

8.0.5 Place a layer of silicone grease around the inside diameter of the grommet where the cable will seat.

8.0.6 Install the grommets on the cable with the Square end flush up against the strain relief placed earlier and face the grommet slit up.

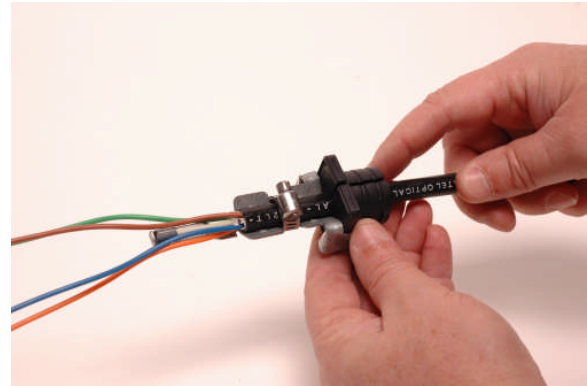

Figure 13

NOTE: Squeeze the two strain relief clamps tight to the grommet flange

8.0.7 Apply a thin layer of Silicone Grease to the gaskets entire surface of the lower and upper end plates of the closure. *See Figure 14*

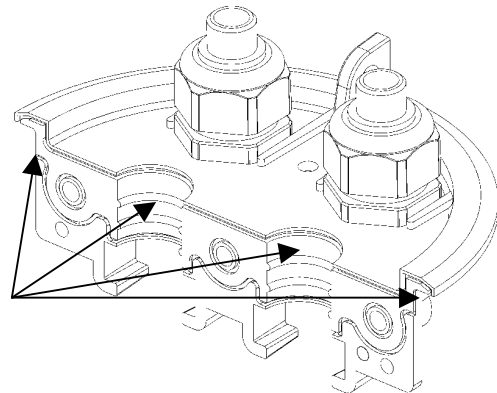

Figure 14

8.0.8 Apply a liberal layer of Silicone Grease on the exterior surface of the grommet and lower the assembly down into the lower end plate of the closure. *Refer to Figure 15*

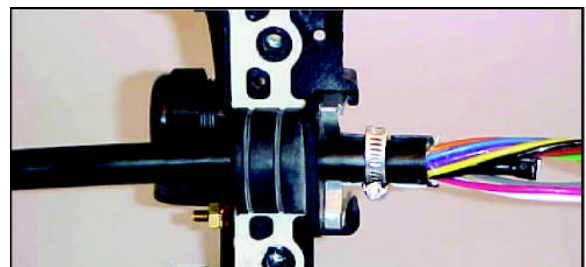

Figure 15

8.0.9 Complete the second cable following the same procedure.

8.1 End Plate Assembly

8.1.1 Align the top end plate to the bottom and gently ease the two multicentric grommets into their storage position.

8.1.2 Install the three Bolts and Nuts and gently start all three.

8.1.3 Starting with the center bolt tighten the bolt until it is snug.

8.1.3 Tighten the remaining two end plate bolts.

NOTE: If adding a Branch/Lateral cable or optical drop cables refer to the following.

8.2 Installation of Branch/Lateral Cables

8.2.1 These cables are sealed using a compression style grommet with a number of sized openings for the different OD or Multiple cable entries.

8.2.2 Determine the OD and number of cables to be installed using Table 1 in an earlier section.

8.2.3 Open up and remove up to 96" of sheath from cables

8.2.4 Select the proper grommet and install the grommet into the cable port by first backing off and removing the blank port plug and domed nut. All ports are equipped with the cable port feed through and blank port plug at the factory. The feed through has a insert that accommodates cables with an OD of .35" to .65" which will be removed for cables under .35" and replaced with a insert which will fit cables .28" to .34". Refer to figures 16 and 17



Figure 16



Figure 17

8.2.5 Slide the dome nut up and over the end of the cable(s). Refer to Figure 18 (Exploded view of assembly)



Figure 18

NOTE: The Strain relief clamp designed for the Branch/Lateral cable installation is installed over the exposed thread of the dome feed thru connector and secured using the metal nut supplied with the kit. Orient the strain relief clamp with the back facing the Multicentric (figure 19), the interior of the closure (figure 20) or sideways out towards the "o" ring groove (figure 21) but NOT DOWN since it may interfere with the installation of the dome. Refer to Figures 19 thru 21



Figure 19



Figure 20



Figure 21

8.2.6 Secure the cable to the strain relief clamp by installing the hose clamp supplied in the kit around the cable and strain relief clamp.

8.2.7 Trim and secure the CSM to the clamp by sliding the CSM between the nut plate and strain

relief clamp. (If central Core Tube cable or Drop cable, Remove the Bolt and CSM plate)

8.2.8 Slide the dome nut up and carefully thread the nut onto the feed through.

8.2.9 Tighten the dome nut fully by hand. Torque the dome nut to 44 in. lbs by hand.

After all Branch/Lateral/Drop cables are installed the remainder of the closure can be assembled.

9.0 Closure Re-assembly & Splicing

9.1.1 Align the Slack Basket back onto the assembled end plates and re-install the two #2 Phillip Head screws removed earlier.

NOTE: Hand start the two screws to prevent cross threading.

9.1.2 Open up the hinge tray storage plate and route all fiber bundles in a counter clockwise direction securing the bundles as you go using the twist loks supplied. Refer to Figure 22

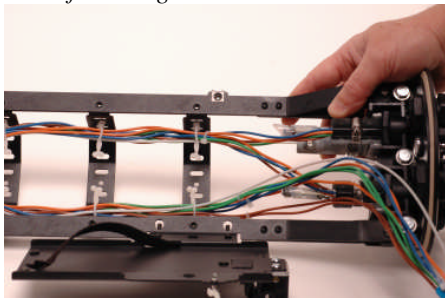

Figure 22

9.1.3 Secure any un-cut or bundles that will not be used in the slack storage basket.

9.1.4 Close the hinged plate and secure using the quarter turn latch. Refer to Figure 23

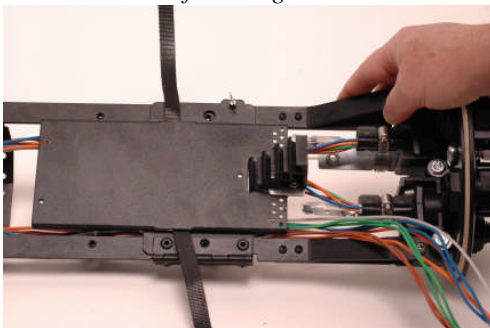

Figure 23

9.1.5 Install the required trays one at a time and secure all fiber bundles using the tie wraps supplied. The trays can be temporarily stood upright using the locking design of the Tray Stacking Module. Refer to Figure 24

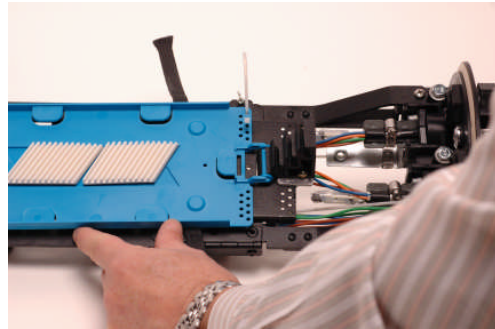

Figure 24

9.1.6 Splice all optical fibers following standard procedures. Rout all fibers within splice trays as referenced in the tray instructions. Refer to Figure 25

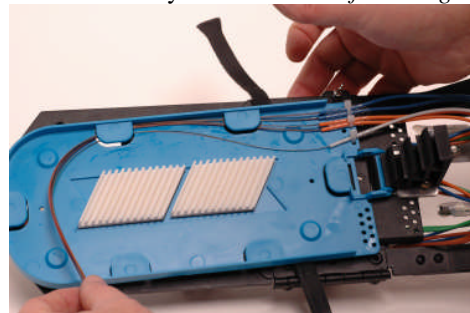

Figure 25

9.1.7 Secure all trays using the Velcro straps supplied. Refer to Figure 26

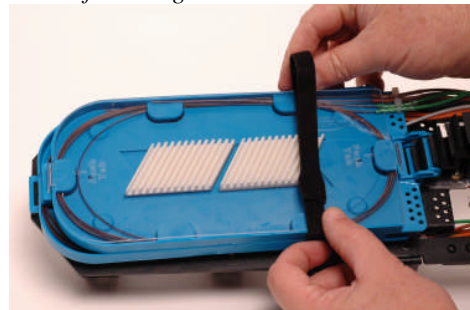

Figure 26



10.0 Closure Closing and Storage

10.0.1 Route all bond/ground wires to the brass stud on the bottom endplate, and secure with the nut and washer pre-installed on the stud.

10.0.2 Locate and install the "O" ring and ensure that it is fully seated around the joined end plates.

10.0.3 Apply a thin film of silicone grease to the entire surface of the "O" ring.

10.0.4 Slide the Dome up and over the splice tray stack and Slack Storage Module.

10.0.5 Align the dome's front hangar support with the end plate support.

10.0.6 Inspect the "O" ring to ensure it is in proper position. Then assemble the "V" band over the Dome and End Plates. Hand start one bolt of the "V" band first and then start the other.

10.0.7 Inspect the "V" band for proper positioning. If all is OK then using a 3/8" nut driver or ratchet and socket tighten both bolts alternating as you tighten until the plastic "V" band halves are fully closed.

10.0.8 Apply 5 PSIs to the End Plate "F" valve.

10.0.9 Apply "E" pressure testing solution or equivalent around the circumference of the "V" band, around all cable ports, and to the End Plate seam. If no leaks are detected, install the appropriate mounting bracket if required. If any leaks are detected re-install or tighten components as required.



580 Ternes Avenue
Elyria, OH 44035
Tel: 440-366-6966
Fax: 440-366-6802
E-mail: engsupport@multilinkone.com
www.multilinkone.com