

Dome Splice Enclosure Installation Instructions

Contents

1	Revision History	1
2	General	1
3	Specifications	3
4	Contents	4
5	Cable Preparation	5
6	Closure Preparation	6
7	Sheath and CSM Retention	7
8	Cable Seal Installation	8
9	Closure Closing and Storage	9

1 Revision History

Release#	Date	Remarks
1.0	11/18/03	Initial Release

2 General

2.1 Overview *Refer to Figure 1*

The Multilink Dome Splice Enclosure (DSC) is a fully sealed high capacity dome style fiber optic splice closure designed for traditional optical fiber splicing and FTTH applications. The closure can be installed in Aerial, Underground, wall, or pole mount applications and supports the various types of cable designs and splicing methods. Incorporated into the closure is a sealing system that requires no special tooling, mastics, adhesives nor thermal sealing products. All cabling is individually sealed allowing for entry or re-entry to the closure without disturbing existing cabling. The DSC consist of six (6) primary components.



Figure 1

2.2 Split End Plate

Split End Plate (Refer to Figure 2) – Allows for installing mid-accessed cables. Split end plates are gasketed and secured to one another with three hex head bolts. End plates have two feeder/express ports, four branch/lateral/drop ports, a bonding and grounding lug, and an “F” pressure-testing valve. Additionally, the endplate supports the installation of closure support bracketing for aerial, wall, or below-grade mounting.

2.3 Slack Basket

Integrated Slack Storage Basket – Designed to allow the storage and routing of all types of fiber bundles. Hinged cover to allow for ease in accessing and managing stored slack. Cover can be installed to hinge from either side of the basket.

2.4 Stacking Module

Tray Stacking Module – Secures up to (8) eight Universal hinged style dome fusion trays. The module has a tray-locking feature that permits each of the splice trays to be hinged and locked in a temporary position to allow access to the individual fibers in trays beneath.

2.5 “O” Ring

“O” Ring – Provides for a seal between the Dome and Split End Plates.

2.6 “V” Band

“V” Band – Adjustable Stainless steel “V” band secures the Dome to the Split End Plates. The “V” band has a feature that supports a locking mechanism for field security.

2.7 Dome

Dome – Protects the internal components and allows for 360-degree access to the splice.

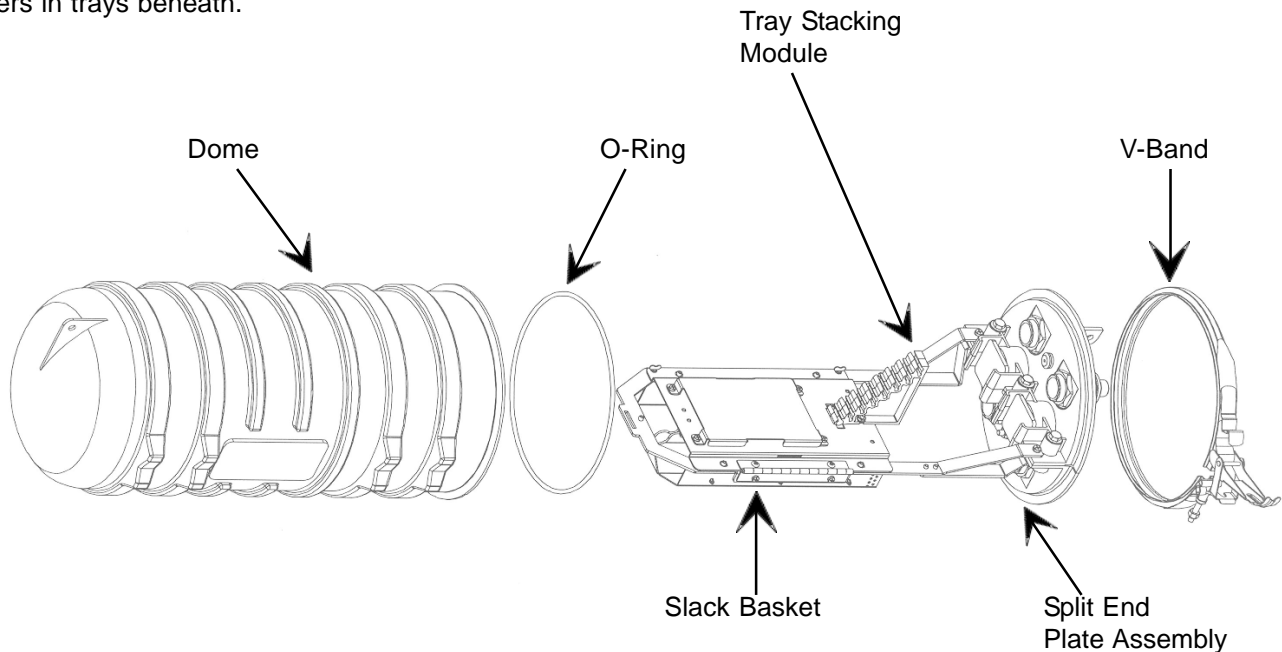

Figure 2, 6 Primary Components

3 Specifications

3.01 Cable Entry

Cable Entry Refer to Figure 3

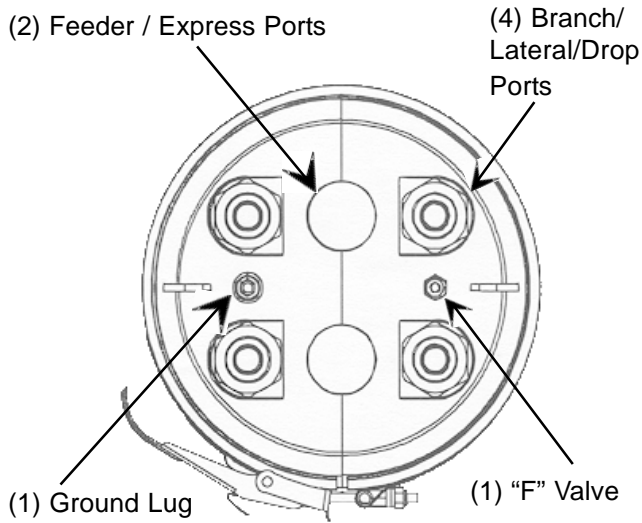

Figure 3

Dome Fittings & Inserts for Branch/Lateral/Drop Cables



Maximum Cable entries – 6*

Feeder/Express (2) ports:
.375" to 1.125" (9.5mm) to (28.6mm).

Branch/Lateral/Drop (4) ports:
.30"-. 98" (7.6mm) to (24.8mm)

*Multiport grommets for supporting up to 6 fiber drops per port for FTTH are available



Part Number	Description
DFK-01-10	Dome Fitting Replacement kit, includes lock nut, "O" ring, & Insert for .71-.98" Dia. Cable
SNP-01-10	Blank Port Plug, Solid Nylon plug fits into above dome fitting kit
DCG-26-10	6 Hole Insert for .21-30" Dia. Cables
	4 Hole Rectangular Insert for Corning/Sumitomo Drop Cables
	Branch/Lateral/Drop Cable insert for .3-.4" Dia. Cable
FCG-50-10	Branch/Lateral/Drop Cable insert for .41-.5" Dia Cable
FCG-79-10	Branch/Lateral/Drop Cable insert for .51-.79" Dia. Cable
DCG-37-10	Drop Cable Grommet for .29-.41 OD Cable (4 Ports)
DCG-35-10	Drop Cable Grommet for .28-.39 OD Cable (4 Ports)
NOTE: Additional Inserts are available, Call supplier for details	

3.02 Closure Dimensions (Refer to figure 4)

Length	22.0" (55.8cm)
Diameter	10.0" (25.4cm)
Weight	9.0 lbs. (4.08 kg)

3.03 Tray & Splice Capacity

- *(8) Dome Fusion trays
- (192) Single fused fibers
- (384) Mass Fused fibers

**NOTE: An optional Interconnect Module and Passive Splitter bracket will effect total splice capacity*

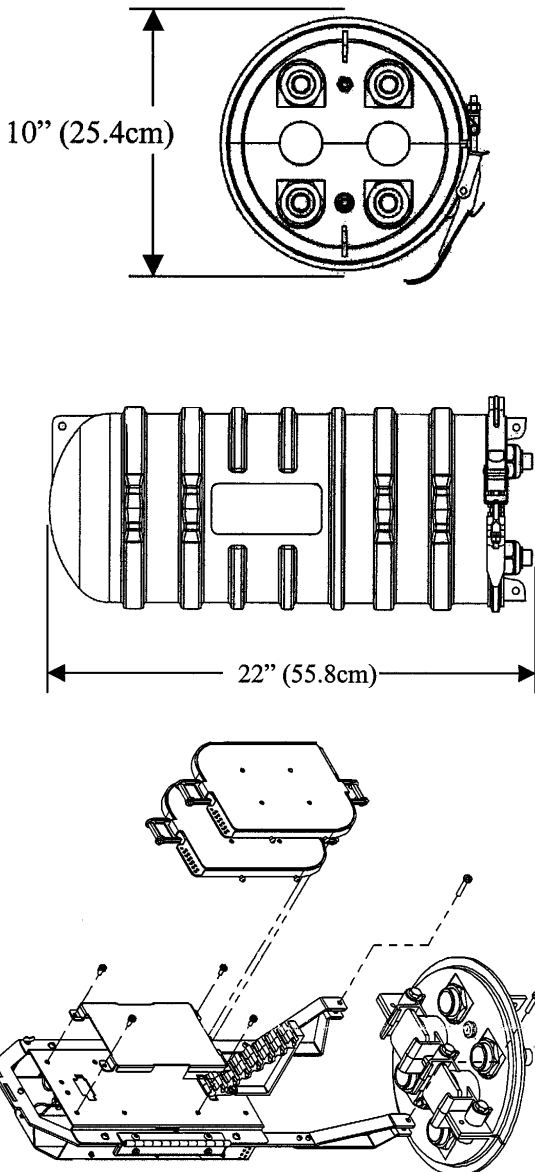

Figure 4

4 Contents

4.01 The basic closure is equipped with the following:

- (1) Complete closure (Dome, O Ring, V Band, End Plates, Slack Storage Module)
- (2) Multicentric Cable seals (Feeder/Express ports)
- (4) Dome fittings for .71-.98 diameter cable with blank plugs
- (1) Grounding/Bonding kit for 3 cables (RUS Compliant)
- (2) CSM/Strain relief brackets for feeder/express cabling
- (3) Silicon Gel packages (1 oz each)
- (2) Dome Fusion trays

4.02 Additional Material Required

- Cable Cleaner or wipes
- Cable identification markers
- Pressure testing solution or equivalent
- Splice sleeves or other splicing specific materials

4.03 Tools Required

- Splicing Shears
- Splicing Equipment
- Cable Stripper
- ½" Inch Wrench or Nut Driver
- Air Pressurization Source

5 Cable Preparation

5.0 Cable Preparation (Refer to figure 5 + 6)

The closure is designed for mid-accessed and full cut cable entries. The following information serves as a guideline for sheath opening lengths.

5.1 Mid-Accessed or Full Cut Cables

Remove up to 120" (47.24cm) of sheath exposing the underlying kevlar, cable loose tubes, core tube or other fiber protective tubing. If armored, refer to section 7.

5.1.1 Cut central or outer strength members' 5.0" (127mm) from the sheath end (will be trimmed later)

5.1.2 Clean the optical bundles or outer buffer tubes with an approved cable cleaner.

5.1.3 Do not expose any fibers at this time.

5.02 Bundle Preparation – For loose tube bundles, depending on the cable manufacturer, the loose tubes may be routed directly to the appropriate splice tray and can be opened and trimmed after installation within the closure. Core tube cables, remove the core tube to within 7.0" (177.8mm) from the end of the cable sheath or armor. This tube will be routed and secured into the slack storage basket and all bundles managed within the basket later.

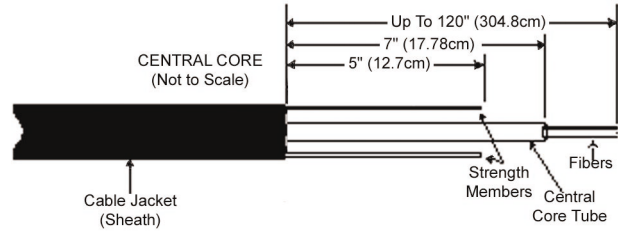

Figure 6. Central Core Cable Preparation

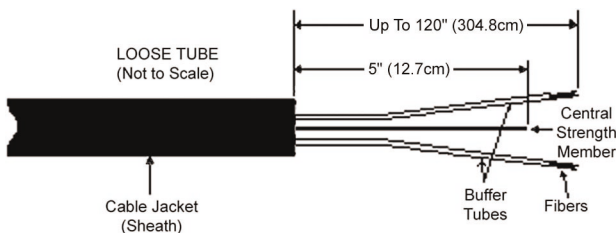

Figure 5. Loose Tube Cable Preparation

6 Closure Preparation

The closure must be disassembled for installing the feeder/express cables into the multicentric grommets. (Refer to Figure 7)

- 6.01 Unlatch the "V" band and remove.
- 6.02 Slide the Dome and "O" ring off and protect the "O" ring from contamination
- 6.03 Remove the two bolts securing the Slack Storage Basket and set all aside.
- 6.04 Back off the three hex head bolts using a ½" wrench or nut driver securing the End plate sections and expose the two multicentric grommets.
- 6.05 Remove the two grommets.

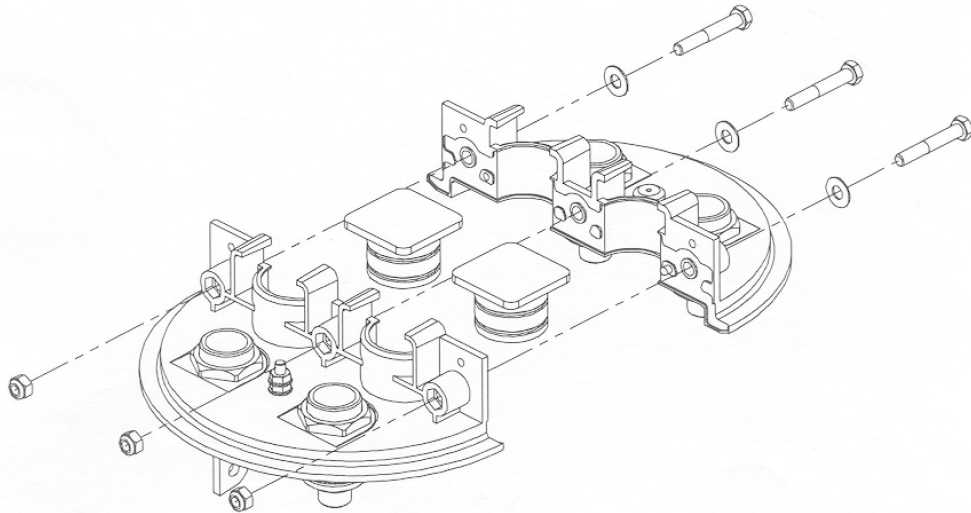

Figure 7. Exploded View Of End Plate Assembly

7 Sheath and CSM Retention

The following information provides installation information regarding the different types of cable sheath and bundling designs. Note that the CSM clamp provides both cable strain relief and CSM termination. If Core Tube cabling is being installed the CSM extension of the combination clamp will be removed.

7.1 Shield Bonding

Armored cable preparation requires the completion of the following steps: (refer to figure 8)

- Step 1 Armored Cable; Slit a 1" long slit under the armor and polyethylene sheath on the opposite side of where the bond connector is to be installed and 90 degrees away from the top and bottom.
- Step 2 Slide the supplied 3M Mini Bonding Connector's bottom up to the sheath's end ensuring that it is under the armor between the optical bundles or core tube and the armor.
- Step 3 Attach the connector top plate and nut to the bond clamp and tighten
- Step 4 Attach the perforated bond wire to the stud of the clamp and gently tighten the second nut.

NOTE: The opposite end of the bond wire will be attached to the closure's end plate in a later step.

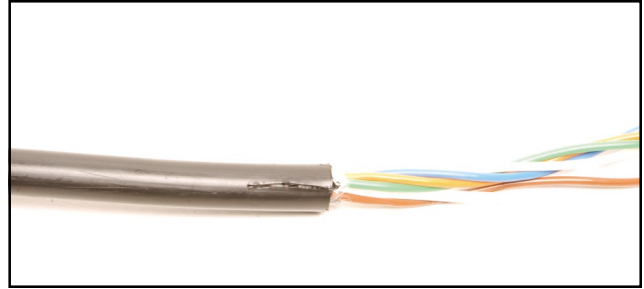

Step 1

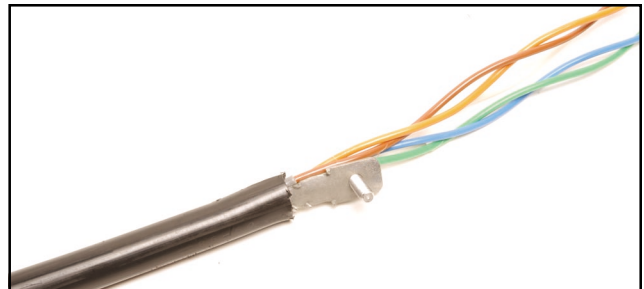

Step 2

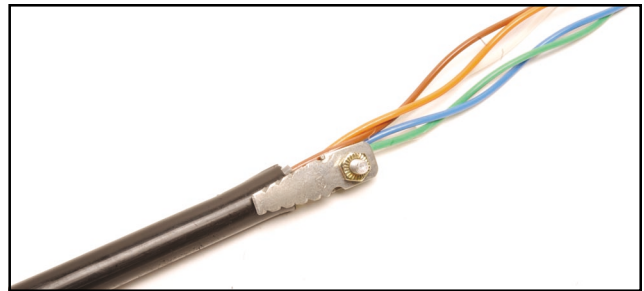

Step 3

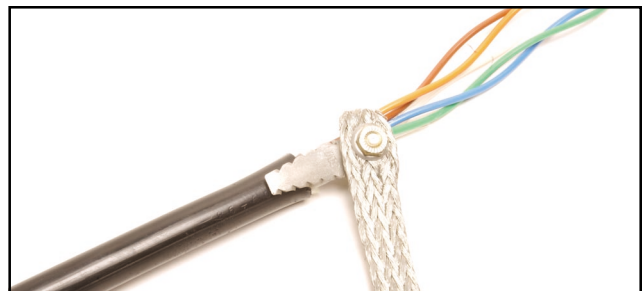

Step 4



Mini Bond Clamp

Figure 8, Shield Bonding

7.2 Sheath Strength Member Termination

Loose tube cables typically have a Central Strength Member that must be terminated to inhibit any movement.

NOTE: For Outer Strength member cables, cut the strength member's flush to the sheath end. See figure 9 for the following steps.

Step 1 Trim the loose tube strength member to 2.5" from the sheath's end.

Step 2 Slide the Cable Retention and CSM clamp over the CSM's end and secure the assembly to the cable sheath using one of the supplied Hose Clamps. Tighten the clamp but do not overtighten.

Step 3 Using a standard pair of pliers, crimp the CSM clamp end to secure it to the CSM.

Step 4 For Central core cables, break-off the CSM extension of the CSM clamp leaving the strain relief intact.

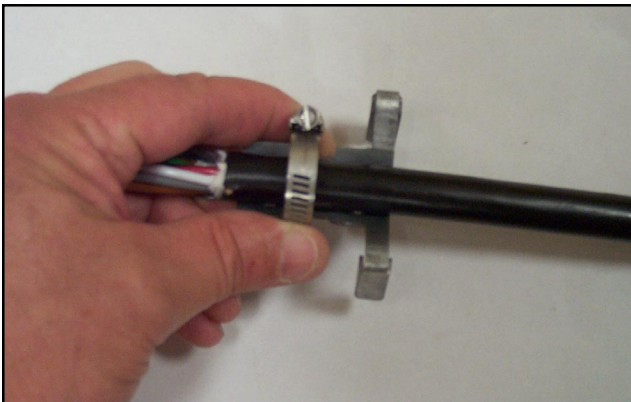
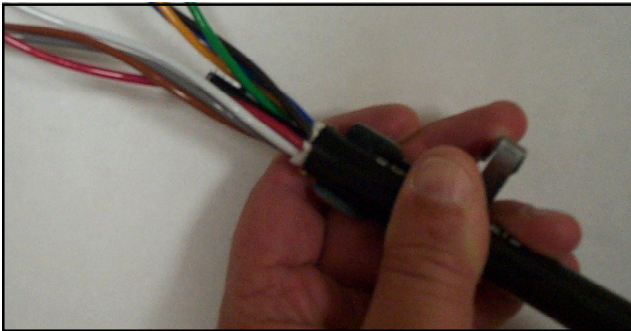
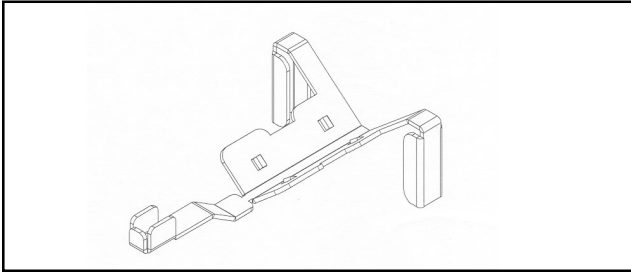

Figure 9

Sheath + Strength Member Termination

8 Cable Seal Installation

8.1 Cable Seal Installation – Express/Feeder Multicentric Grommet Seals

Refer to Figures 10, 11, and 12

- 8.1.1 Using the measuring gauge provided in the closure kitting, follow the directions on the gauge and determine the diameter of the feeder/express cable(s) and number of layers to be removed.



Figure 10

- 8.1.2 Use caution when removing layers. Splicing shears or a cable knife may be used to start the removal by placing a small nick at the point where the layer joins the grommet.



Figure 11

Pull on the layer at the location of the nick.



Figure 12

- 8.1.3 Any differential between the OD of the cable and the adjusted ID of the grommet can be made up with a layer of sealing tape. (Not provided in kitting)
- 8.1.4 Place a layer of silicone grease around the inside diameter of the grommet where the cable will seat.
- 8.1.5 Install the grommet on the cable with the Square end flush up against the strain relief placed earlier. Face the grommet slit down.
- 8.1.6 Apply a thin layer of Silicone Grease to the gasket surface of the lower end plate of the closure.

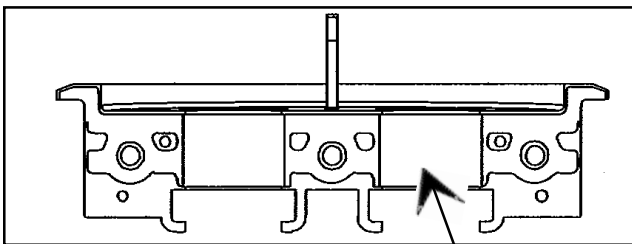

Figure 13

Figure 13. Apply Silicone Lubricant to the entire gasket surface

- 8.1.7 Apply a liberal layer of Silicone Grease on the exterior surface of the grommet and lower the assembly down into the lower end plate of the closure.
- 8.1.8 Complete the second cable following the same procedure.



Figure 14

8.3 End Plate Assembly

- 8.3.1 Align the top end plate to the bottom and gently ease the two Multicentric grommets into their storage position. See Figure 15

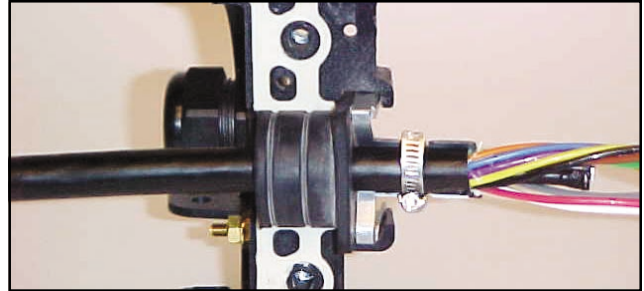

Figure 15

- 8.3.2 Install the three Bolts and Nuts and gently start all three.
- 8.3.3 Starting with the center bolt, tighten the bolt until it is snug.
- 8.3.4 Tighten until snug the remaining two end plate bolts. Torque all bolts to 40 inch pounds.

8.4 Branch/Lateral/Drop

- 8.4.1 These cables are sealed and strain relieved using a compression style grommet. There are a number of sized openings for the different OD or Multiple cable entries.
- 8.4.2 Determine the OD and number of cables to be installed using the Table found in **Figure 3**
- 8.4.3 Open up and remove up to 120" of sheath from cables
- 8.4.4 Select the proper grommet and install the grommet into the cable port by first backing off and removing the domed nut. All ports are equipped with the cable port feed through and Black insert at the factory. The black insert must be used for cables with a OD of .71" to .98" and is also used for sealing the blank port plug. If the cable OD does not fit that range or a blank port plug is not to be installed into this port, using a pair of needle nose pliers remove the black insert and place aside.
- 8.4.5 Select the appropriate insert from the table found in Figure 3 and insert into the dome fitting. (See Figure 16)
- 8.4.6 Slide the dome nut up and over the end of the cable(s).



Figure 16



8.4.7 Slide the cable end(s) into the appropriate grommet cable port.

Note: If the cable has a CSM; (Branch/Lateral Cables will require a CSM/Cable retention kit. Drop cables do not require any additional kits.) Follow the previously detailed instructions for assembly of the CSM Clamp.

8.4.8 Allow drop cables to extend approximately 2.0" into the closure.

8.4.9 Slide the dome nut up and carefully thread the nut onto the feed through.

8.4.10 Tighten the dome nut fully by hand. Torque the dome nut to 44 inlbs by hand or using the Dome Nut wrench. **DO NOT USE ANY OTHER TYPE OF WRENCH**

After all Branch/Lateral/Drop cables are installed the remainder of the closure can be assembled.

8.4.11 Route all bond/ground wires to the Brass ground stud and terminate as required.

8.4.12 Align the two bolt holes of the Slack Storage Basket to the end plate mounting holes and secure with the supplied hardware. (See Figure 4)

8.4.13 Align the hinged Slack Storage Basket cover to hinge in the desired hinging direction. Remove and re-install the Tray Storage Module as well.

8.4.14 With the cover in the open position, store all slack in the Slack Storage Basket and secure using the supplied Twist Loks. Bundles can be secured to the basket using the supplied Tie wraps in the holes as required.

8.4.15 Determine the routing and transition requirements of the bundles to be spliced.

8.4.16 Install the required trays one at a time and secure all fiber bundles using the tie wraps supplied. The trays can be temporarily stood upright using the locking design of the Tray Stacking Module.

Note: Trays must be inserted parallel to the groove in tray stacking module.

8.4.17 Splice all optical fibers following standard procedures. Route all fibers within splice trays as referenced in the tray instructions.

8.4.18 Secure all trays using the Velcro strap supplied and ensure that the two ¼ turn Slack Storage Module latches are properly latched.

9 Closure Closing and Storage

9.1 Dome Installation

9.1.1 Locate and install the "O" ring and ensure that it is fully seated around the joined end plates.

9.1.2 Apply a thin film of silicone grease to the entire surface of the "O" ring.

9.1.2 Slide the Dome up and over the splice tray stack and Slack Storage Module.

9.1.3 Align the dome's front hangar support with the end plate support.

9.1.4 Inspect the "O" ring to ensure it is in proper position. Then slide the "V" band up and over the Dome and End Plates. Latch the "V" band.

9.1.5 Inspect the "V" band for proper positioning. If all is OK then apply 10 PSIs to the End Plate "F" valve.

9.1.6 Apply "E" pressure testing solution or equivalent around the circumference of the "V" band, around all cable ports, and to the End Plate seam. If no leaks are detected, install the appropriate mounting bracket if required. If any leaks are detected re-install or tighten components as required.